



# UNIlab

## WORKSTATION



PICTURE SHOWS PRODUCT WITH OPTIONS

INERTGAS TECHNOLOGY

- Ready to operate workstation, incl. main antechamber and vacuum pump
- 2 glovebox sizes available
- PLC controlled with Siemens touch panel
- Automatic regenerable H<sub>2</sub>O/O<sub>2</sub> single purifier unit
- Attainable purity <1 ppm H<sub>2</sub>O, <1 ppm O<sub>2</sub>
- Stainless steel encapsulated blower **MB- BL-01** with frequency converter
- Circulation capacity more than 84 m<sup>3</sup>/h (50 cfm) at  $\Delta P = 60$  mbar (60 Hz)
- World-wide operation using standard power supply
- Integrated high vacuum feedthroughs
- Conforms to **CE**

•  **US LISTED**

## Technical Data

### General Data

**Product:** Inert gas system UNILAB

**Type:** Glovebox with gas purification system

**Size:** Various sizes available, see page 5

### System Control

**Control unit:** Programmable logic controller (PLC)

**Operation:** 5.7" monochrome touch panel with simulated multi-language operation elements for all glovebox components, foot pedal for box pressure adjustment

**Electrical power:** 230 V/50-60 Hz, 10 A or 115 V / 50-60 Hz, 20 A or 100 V/ 50-60 Hz, 20 A (power consumption may vary dependent on accessories)



Touch Panel TP 170 mono

## Gas Purification

### Process

**Gas circulation:** Closed loop gas recirculation

### Gas Purification System

Removal of H<sub>2</sub>O and O<sub>2</sub>

### Working Gas

**Inert gas:** Nitrogen, Argon or Helium

### Attainable Purity

H<sub>2</sub>O < 1 ppm, O<sub>2</sub> < 1 ppm

### Purifier

**Amount / type:** 1 H<sub>2</sub>O / O<sub>2</sub> purifier column

**Capacity:** Oxygen removal: 30 l (standard conditions), moisture removal: 1300 g

**Material:** Stainless steel type 1.4301 (US type 304)

**Heater:** Integrated

## Gas Purification

### Regeneration

The purifier unit is regenerable

**Procedure:** Autom. regen. program (PLC controlled)

**Regeneration gas:** N<sub>2</sub>/H<sub>2</sub> mixture (H<sub>2</sub> 3-5 %) or Ar/H<sub>2</sub> mixture (H<sub>2</sub> 3-5 %)

### Cooling

**Type:** Water cooling 2-3 l/min\* (water pressure 200-300 kPa) (in case of excess heat generation inside glovebox additional box integrated heat exchangers are available)

\*Chiller ULK 1000 on request

### Circulation Unit

**Type:** Integrated blower MB-BL-1 vacuum-tight, oil-free

**Flow rate:** 84 m<sup>3</sup>/h (50 cfm) at ΔP = 60 mbar (60 Hz)

**Features:** Operated with all standard power supplies; optimum system tuning by frequency pre-selection for the blower

### Vacuum Pump

**Type:** Rotary vane pump\*, oil mist filter, oil recirculation, automatic gas ballast control

**Operation:** 12 m<sup>3</sup>/h (10,9 cf/m at 60Hz), dual stage, ultimate vacuum < 3 x 10<sup>-2</sup> mbar

\*Dry pump on request

### Valves

**Main valves:** Electro-pneum. valves MB EPV-40 DN 40

**Control valves:** MB LogicSVB magnetic valve system, DN 4/8

### Piping

**Main piping:** Copper pipe DN 40 KF system\*

**Control pipework:** Copper pipe DN 4/10\*

\*Stainless Steel pipe 1.4301 (US type 304) on request

### Integral Leak Rate

Less than 10<sup>-5</sup> mbar l/s

## Purifier Performance

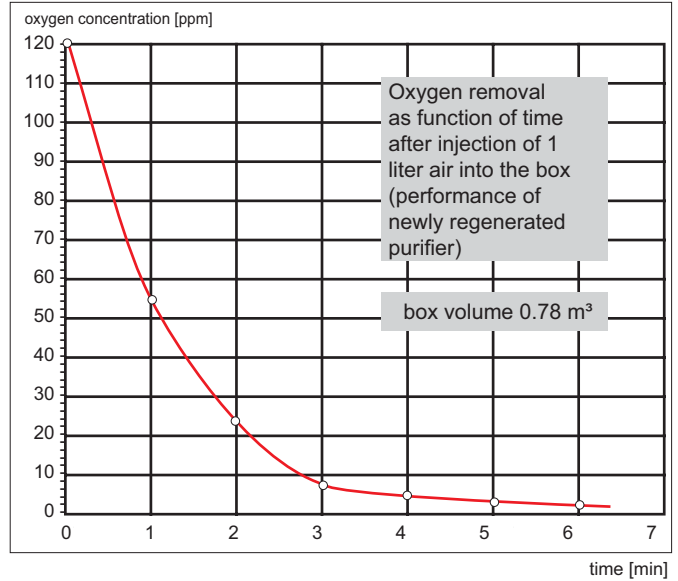
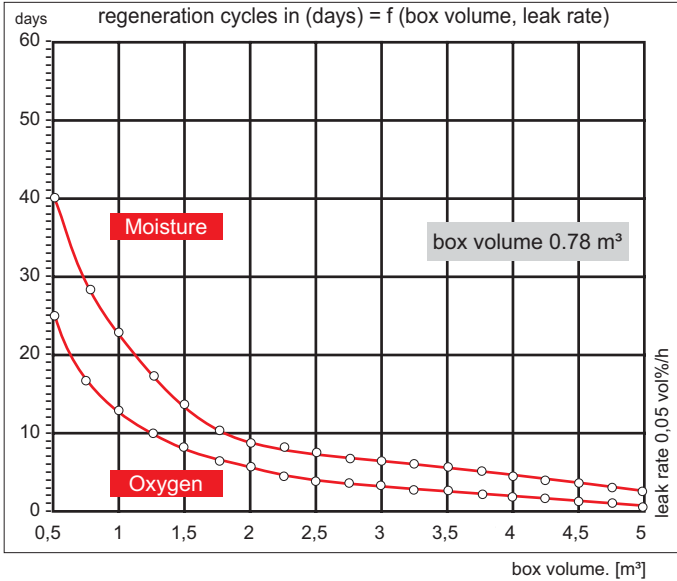

### Glovebox

#### Type

Glovebox with bolted side panels

**Material:** Stainless steel 1.4301 (US type 304), thickness 3 mm

**Inside surface:** Brushed finish  $R_a < 1 \mu\text{m}$  (DIN ISO 1302)

**Outside surface:** Coated, grey (RAL 7035)

**Glovebox inside dimensions:** width: 1200 mm / 1950 mm, height: 920 mm, depth: 780 mm

#### Feedthroughs

**DN 40 KF:** 4 pieces for customers usage (e.g. electrical feedthrough)

**Electrical feedthrough:** KF40 included (100, 110 or 230 V)

#### Dust Filter

**MB-BF-L-03<sup>®</sup>** 0.3  $\mu\text{m}$ , class H 13, 1 gas inlet filter / 1 gas outlet filter

#### Shelves

**3 shelves:** Stainless steel 1.4301 (US type 304) height adjustable

**Dimension:** length: 1000 mm, depth: 220 mm

#### Box Windows

**Inclined panel:** Lexan thickness 10 mm\*  
\*safety glass on request

### Glovebox

#### Glove Ports

**Type:** POM (Polyoxymethylen) 220 mm dia., O-ring sealed

#### Gloves

**Material:** Butyl, thickness 0.4 mm\*

\*other sizes and materials on request

#### Box Light

**Fluorescent lamp:** Front mounted

#### Gas Purification System

Removal of  $\text{H}_2\text{O}$  and  $\text{O}_2$

#### Working Gas

**Inert gas:** Nitrogen, Argon or Helium

#### Leak Rate According to ISO 10648-2 (Oxygen Method)

< 0.05 vol%/h typical (Class 1, measured at final acceptance test)

#### Leak Rate According to ISO 25412 (Press. Change Method)

< 0.05 vol%/h at negative pressure of 10 mbar at constant temp. (measured at final acceptance test)

## Main Antechamber

### Type

Cylindric type antechamber\* 390 mm diameter, length 600 mm (inside dimensions)

**Material:** Stainless steel 1.4301 (US type 304), thickness 2.5 mm

**Inside surface:** Brushed finish

**Outside surface:** Coated, grey (RAL 7035)

\*rectangular on request

### Sliding Tray

**Material:** Stainless Steel 1.4301 (US type 304)

### Doors

**Material:** Aluminum (AlMg3), anodized, thickness 10 mm

**Door lock:** Easy to operate spindle-lock with lifting mechanism

### Pressure Gauge

**Manometer:** Analog display

### Vacuum / Refill Process

**Handling:** Manual operation via hand valves

## Main Antechamber Operation

### Valves

Hand valves (DN 40 vacuum line / DN 8 refill line)

### Leak Rate

$<10^{-5}$  mbar l/s

## Basic System Configuration

- Glovebox with stand, incl. castors + leveling feet
- Main antechamber
- Gas purification system with vacuum pump RV12
- Shelves
- One piece electrical feedthrough

## Optional Features

The system can be extended with the following optional components:

- Mini antechamber
- Rectangular antechamber
- H<sub>2</sub>O/O<sub>2</sub>-analyzer
- Refrigerator
- Solvent absorber
- Microscope equipment
- Automatic antechamber control
- Mechanical door locks
- Auto purge function
- Stainless steel piping
- Solvent purification systems

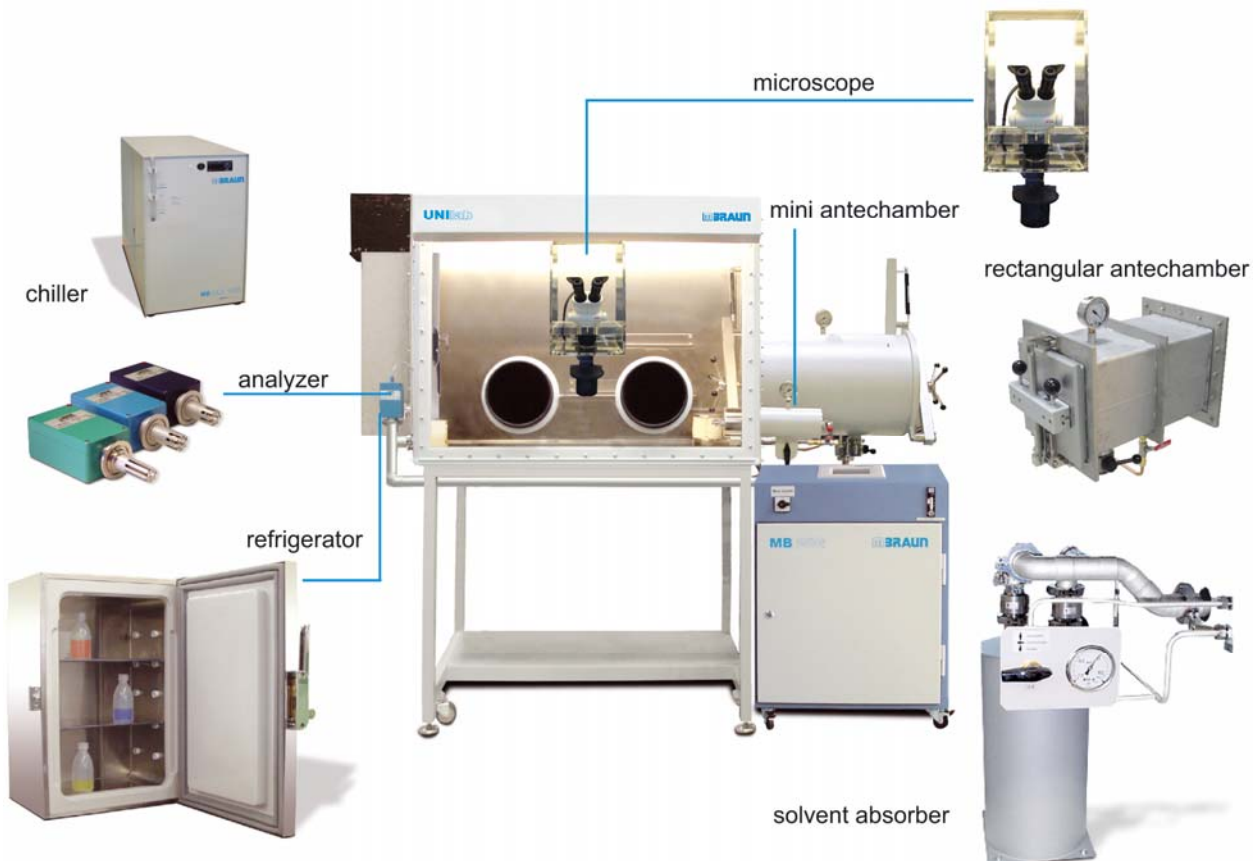

## Dimension

The UNILAB system is available in the following box sizes and depth: outer dimensions (mm), weight: 400 kg/550 kg

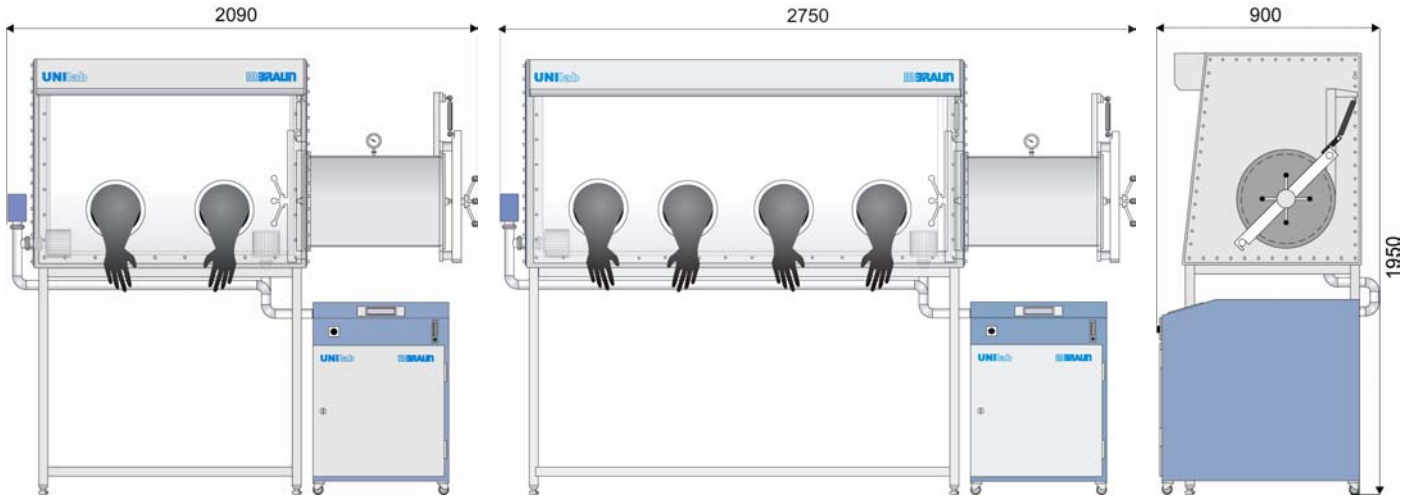

## Utilities

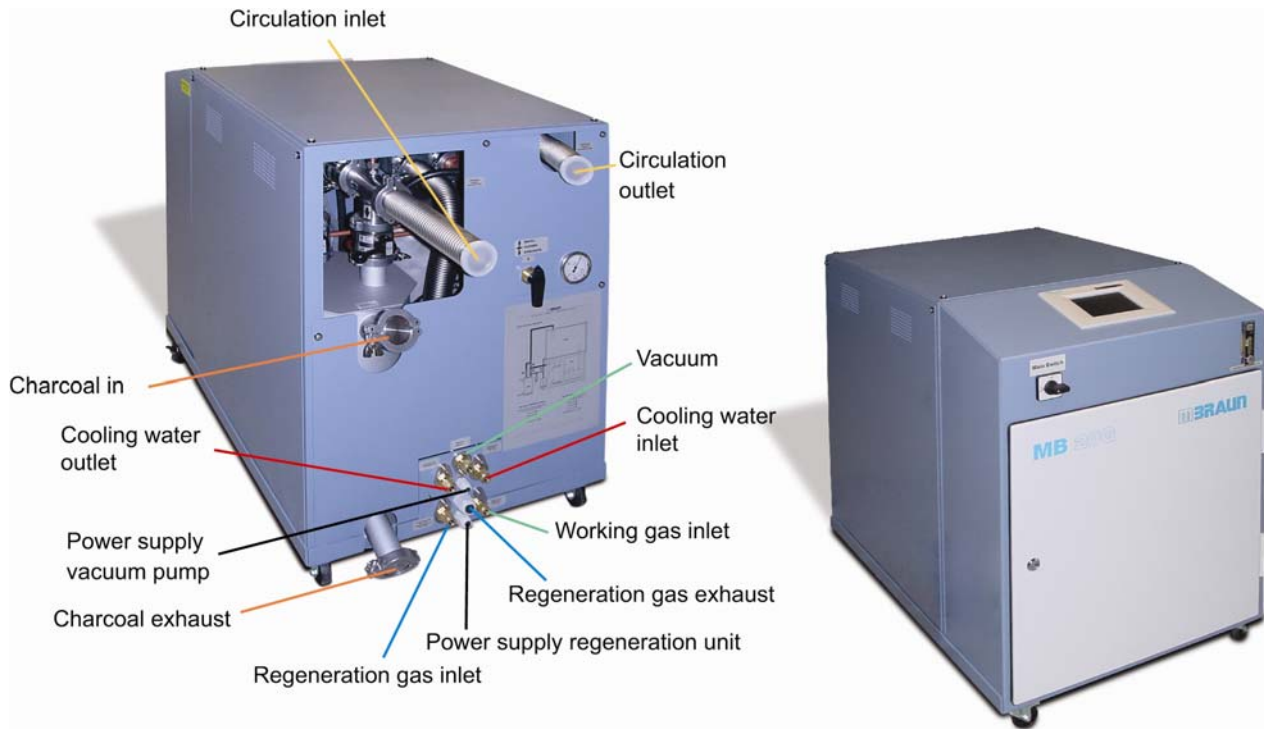

## Utilities

Designation	Medium	Pressure (kPa)	Temp. (°C)	Flowrate (l/min)	Connection Ø
Cooling water inlet, opt. use	Water	300	max. 20	2 - 3	8 mm hose ID
Cooling water outlet		50	max. 32		8 mm hose ID
Working gas	N <sub>2</sub> or Ar 4.8	600		250	Swagelok 10 mm
Regeneration gas	Ar/H <sub>2</sub> 95/5	30 - 50		20 - 25	Swagelok 10 mm
Regeneration gas exhaust	or N <sub>2</sub> /H <sub>2</sub> 95/5				Swagelok 10 mm



## Box Volume Table

approx. 0.8 m<sup>3</sup>

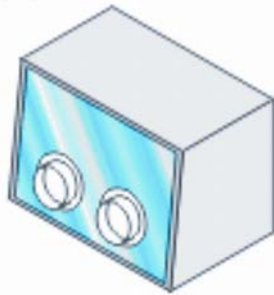

approx. 1.4 m<sup>3</sup>

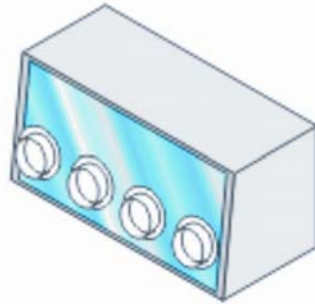

Box depth 780 mm



**M. Braun Inertgas-Systeme GmbH** Head-Office Germany • Dieselstr. 31, D-85748 Garching • Phone: +49(0) 89-3 26 69-0  
Fax: +49(0) 89-3 26 69-105 • E-Mail: [info@mbraun.de](mailto:info@mbraun.de)

**M. Braun Inc. USA** • 14 Marin Way, Stratham, NH 03885 • Phone: +1-603-773-9333 • Fax: +1-603-773-0008 • E-Mail: [info@mbraunusa.com](mailto:info@mbraunusa.com)

**M. Braun Inertgas Systems (Shanghai) Co., Ltd. China** • 828 Xin Jinqiao Road • Pudong Shanghai 201206, P.R.C.  
Phone: +86-21-50320257 • Fax +86-21-50320229 • E-Mail: [info@mbraunchina.com](mailto:info@mbraunchina.com)

**M. Braun Service Japan** • Yoshikawa building, 3rd floor • 6-32 Honcho, Wako-shi • Saitama 351-0114 • Phone: +81-48-452-6367 • Fax: +81-48-452-6368

**Internet** [www.mbraun.de](http://www.mbraun.de) • [www.mbraunusa.com](http://www.mbraunusa.com) • [www.mbraunchina.com](http://www.mbraunchina.com)